



Gordon the Big Engine™

Owner's Information

Welcome

Thank you for purchasing this Bachmann **Gordon the Big Engine™** model locomotive. This detailed working replica will give you years of pleasure and reliable operation if it is handled with care and regularly serviced.

Running in

It is necessary that this Locomotive is 'run-in' to allow the mechanism and gears to settle. This requires the model to be run without a load (wagons, coaches, etc.) for 30 minutes in each direction at half speed.

Lubrication

All Bachmann model locomotives are supplied ready lubricated and can be used straight from the box. Over time your locomotive will require some additional lubrication, when will depend on the frequency of use and storage, so please inspect your model on a regular basis.

Please note: A plastic compatible lubricant is required. Suitable products from both the Bachmann Trains & Woodland Scenics ranges are available from your local Bachmann retailer.

Next18 DCC Decoder Fitting

Your Bachmann **Gordon the Big Engine™** model locomotive comes ready to be adapted for Digital Command Control (DCC). The conversion of this locomotive to DCC operation is a simple task.

A Next18 DCC Decoder Socket is located on the locomotive chassis inside Gordon's body shell.

Remove the two screws that are positioned at either end of the locomotive chassis, you will need to move aside the front and rear wheels. There is also a Valve Gear Body Clip that will need to be released on each side before removing the body.

Removing the body will expose a small PCB with DCC Socket fixed to the chassis.

Remove the DCC Blanking Plate and replace with a Bachmann E-Z Command Next18 DCC decoder, item number 36-567.

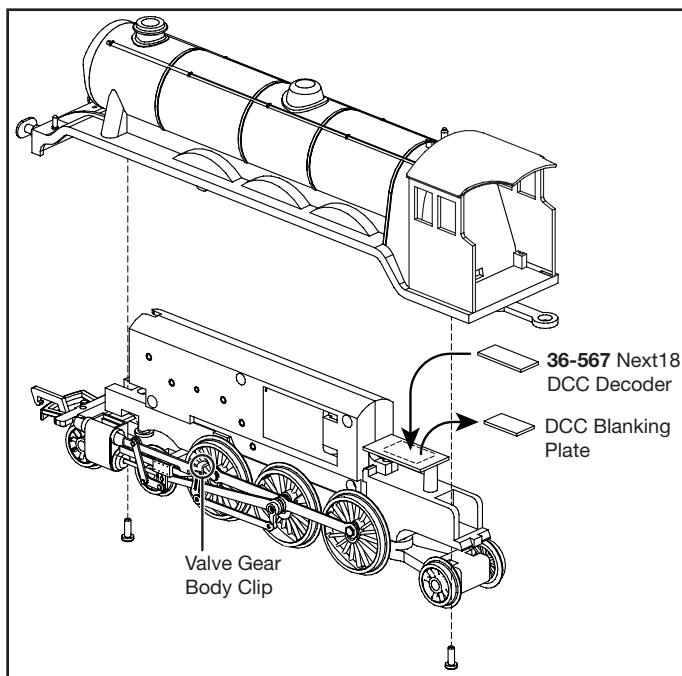

Spare Parts

Selected spare parts are available from the Bachmann Europe Service Department. For further information and enquiries please contact the Bachmann Europe Service Department directly by email on service@bachmann-europe.co.uk or by phone **01455 245575**.

Warranty

This product has a Warranty for 12 months from the date of purchase against faulty materials or workmanship subject to the following conditions. During this period such defects that occur will be repaired or defective parts replaced free of charge.

1. This Warranty applies only if the item was purchased from an authorised retailer of Bachmann Europe PLC ('Bachmann') within the United Kingdom, European Union & European Economic Area. This Warranty does not confer any rights other than those expressly set out above and does not cover any claims for consequential loss or damage. The Warranty is offered as an additional benefit and does not affect your statutory rights as a consumer.
2. For claims under this Warranty, in the first instance the product must be returned to the retailer with evidence of the purchase date in the form of retailer receipt/invoice accompanied by a letter or Service Request form setting out the date and place of purchase, giving a brief explanation of the problem that has led to the claim. It is essential that the claim reach the retailer on or before the last day of this Warranty period. Late claims will not be considered.
3. This Warranty is only available to the original retail purchaser of this product and is non-transferable.
4. The Warranty does not extend to cover damage resulting from misuse or careless handling, accidental damage, wear and tear, or use on a voltage supply other than that stamped on the product.
5. The Warranty may be considered void if repairs have been attempted other than by Bachmann staff.
6. The Warranty is on the original product in its entirety and does not extend to individual components removed from the product. In respect of train sets the warranty applies to motorized units and controllers only.
7. If Bachmann chooses to replace a product it will be with the nearest appropriate model of its choice.
8. Bachmann reserves the right to decline service to any model that has been fitted with a decoder after manufacture.
9. Bachmann will not be held responsible for damage to or loss of an after market decoder fitted to a model submitted for service under the Warranty.
10. The fitting of a Bachmann decoder with a current Warranty shall not be deemed to change the position regarding a product that is otherwise outside its own Warranty. It may be necessary to change decoder settings during service.
11. Bachmann's liability under this Warranty will in no case exceed the price paid for the product as originally manufactured.



Thomas the Tank Engine & Friends™ CREATED BY BRITAIN ALLCROFT
Based on The Railway Series by The Reverend W Awdry. © [Year] Gullane (Thomas) Limited. Thomas the Tank Engine & Friends and Thomas & Friends are trademarks of Gullane (Thomas) Limited.

© HIT Entertainment Limited. HIT and the HIT logo are trademarks of HIT Entertainment Limited.



HIT entertainment



Join us at the **Bachmann Collectors Club**

The Bachmann Collectors Club is the official club for Bachmann enthusiasts. Our aim is to keep members up to date with the latest news and views from Bachmann and give them the chance to purchase and collect exclusive limited edition Bachmann Branchline and Graham Farish products.

Members also receive:

- **Four copies of the Bachmann Times magazine**
- **A personalised membership card and pin badge**
- **An annual club wagon in your chosen scale**
- **First to know about new product with our 'British Railway Announcements' supplement**
- **A FREE copy of the annual Bachmann Model Railway Combined Volume catalogue**
- **A specially commissioned calendar**
- **Invitations to special club events and access to the Members Lounge at certain shows.**
- **Monthly news via our TrainMail e-newsletter**
- **Purchase limited edition exclusive models**

For more information either visit our website at
www.bachmann-collectorsclub.co.uk
or complete the form overleaf and return it to Bachmann Collectors Club.



Warranty Service Request

Please fill in the form overleaf to submit a Warranty Service Request.

- Ensure the form is filled out in full and a brief explanation of the problem is given.
- Proof of purchase date (preferably a receipt) is required.
- Send this form with the product direct to the retailer that you purchased the model from.

Please note: *it is essential that the letter of claim reaches the retailer before the last day of this Guarantee. Late claims will not be considered.*

DCC Decoders

Please note: *any locomotive returned to the Service Department for attention should, if possible, have any decoder removed. If sent with a decoder fitted please reset the address to 3, service may be restricted. Bachmann Europe PLC only accept liability to the value of a standard model. This also applies to body modifications/detailing.*



Bachmann Collectors Club

Membership Information Request Form

Name:

Address:

Town/City: **Postcode:**

Email:

Please return to:

Bachmann Collectors Club
PO Box 7820,
Barwell,
Leicestershire.
LE9 8WZ
England



Warranty Service Request Form

Name:

Address:

Town/City: **Postcode:**

Tel. No:

Email:

Retailer where purchased:

Description of Problem:

.....

.....

.....